

Out-of-plane loading test of anchored masonry veneer to concrete backing

*Jong-Hoon Kwon¹⁾ and Hong-Gun Park²⁾

^{1), 2)} *Department of Architectural Engineering, Seoul National University, Seoul, Korea*
¹⁾ kan0409@snu.ac.kr

ABSTRACT

To investigate an available strength of masonry veneer, cyclic tests for subassemblies and masonry veneer were conducted. Subassemblies consist of two bricks, a concrete block, and a sheet-metal veneer anchor. 16 veneer anchors were installed between backing and masonry veneer. In the masonry veneer test, the veneer showed rigid rotation behavior around the base, and the veneer anchors installed at the top and bottom of the veneer showed different strain by height. Before the bottom anchors reach their maximum strength, the top anchors lose their strength. Therefore, displacement of the veneer occurs with no noticeable increase in the strength of veneer, like yield. The test results showed that the strength of the masonry veneer with 16 veneer anchors was 36% of the strength 16 subassemblies. The available strength of the masonry veneer should be obtained by considering the displacement of the veneer by height.

1. INTRODUCTION

The Korean building code (KBC) have included design specifications of non-structural elements. In the non-structural elements, the masonry veneer with the concrete backing has been applied to various structures in Korea such as residential and school facilities, due to its appealing appearance and cheap construction costs. To prevent the collapse of the masonry veneer, the masonry veneer should be fixed to the backing with a veneer anchor (**Fig.1**). The specifications for masonry veneer suggests an prescriptive requirements for anchored masonry veneer and an alternative design of anchored masonry veneer. Prescriptive requirements provides the area where more than one veneer anchor should be installed and alternative design determines the area where more than one veneer anchor should be installed through the calculation of the engineer. However, due to the lack of test results, there is no way to predict the out-of-plane strength of the anchored masonry veneer.

The subassembly specimens with a wood backing block and a cement brick

¹⁾Graduate Student

²⁾ Professor

backing brick were tested in Choi et al (2004) and Martins et al (2016). Due to the differences of material of the blocks, it is difficult to apply the experiment result to the concrete wall. Also, it is impossible to know what kind of behaviors will be seen in the wall unit because experiments were conducted on individual subassembly only. In McGinley (2008) and Jo (2010), quasi-static test of masonry veneer were performed in out-of plane direction. In each experiment, the backings were wood and cement block, and the out-of-plane strength of the veneer to the spacing of installed veneer anchors

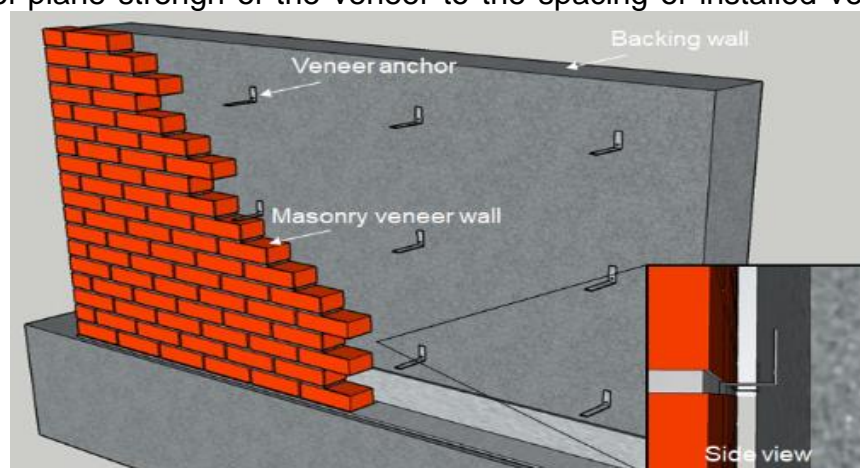

Fig.1 Composition of the masonry veneer anchored in the backing

has been verified. However, the distribution of load from the masonry veneer to the veneer anchors was not analyzed. It made it impossible to examine the relationship between the performance of individual veneer anchors and the performance of masonry veneer. The out-of-plane shaking table experiments were conducted in Graziotti et al (2016), Okail et al (2010), and Reneckis et al (2004). Cement brick and wood were used as backings in Graziotti et al (2016) and Okail et al (2010). Reneckis et al (2004) also used wood as a backing, and the experiment was conducted with a variable as the veneer anchor fixing method. Shaking table test shows the PGA that the wall can withstand and the modes of destruction and behavior of the masonry veneer at the actual earthquake, but there is a limit that the load distributed to individual veneer anchors cannot be known.

To determine the number of veneer anchors to be installed, it is necessary to compare the performance of the veneer anchor in the subassembly and in the masonry veneer. In this paper, the subassembly cyclic tension-compression test and veneer quasi-static test were conducted on L-shaped sheet-metal anchors (**Fig.2**). failure mode and strength of veneer anchor were investigated through the subassembly test. The displacement and strength of the masonry veneer and the strain of the veneer anchor was investigated through the quasi-static test. The effect of the uneven displacement of the masonry veneer wall on the strain of each veneer anchor is analyzed. By comparing the strength of 16 veneer anchors with a veneer wall with 16 veneer anchors installed, out-of-plane strength of the masonry veneer was 36% of the 16 anchors



Fig.2 L-shaped sheet-metal anchor

2. TEST PLAN

2.1 Subassembly test

As shown in **Fig.3**, subassembly specimen consisted of two bricks, a concrete block, and a L-shaped sheet-metal veneer anchor. The veneer anchor was fixed by rawlplug. Concrete block was made of concrete with compressive strength of 35MPa and the mortar with compressive strength of 11MPa was used to connect two bricks. The dimensions of the block cross section was determined to be 140 mm x 140 mm to satisfy the installation recommendation that separation of 70mm or more from the corners of concrete is required. The embedded length of the veneer anchor was 45 mm so that it could satisfy the requirement of Korean building code. 28days after the concrete was poured, the veneer anchor was fixed to the block and the mortar connecting the bricks was also cured over the 28th.

As shown in **Fig.3**, Concrete block and brick were fixed with upper and lower jigs. The jigs was designed to deliver both tensile and compression to the specimen. Displacement transducers and strain gauges were installed to measure displacement of assemble specimen and strain of veneer anchors. The jigs were connected to the UTM and a loading protocol consisting of three reverse cycles was applied. If destruction does not occur after three cycles, the load was increased and the experiment was carried out until the destruction occurred.

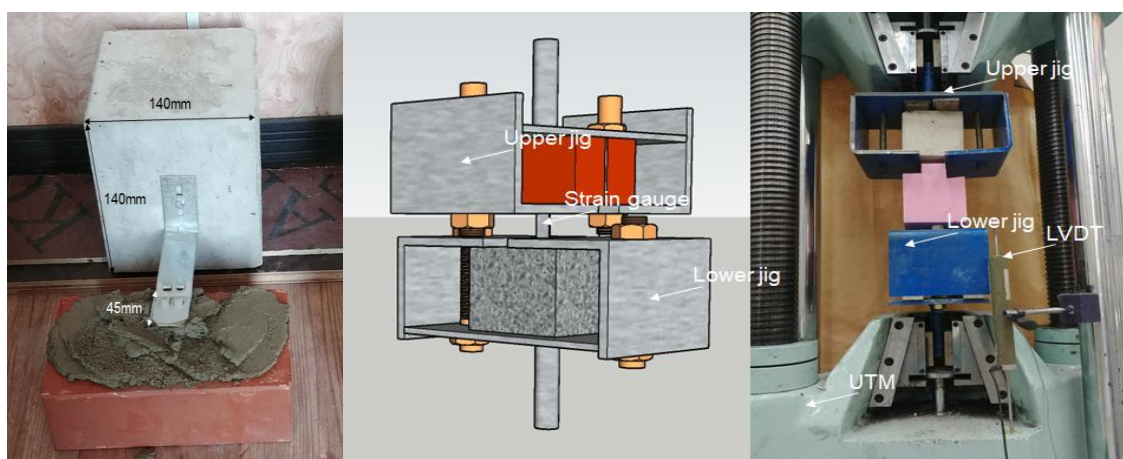
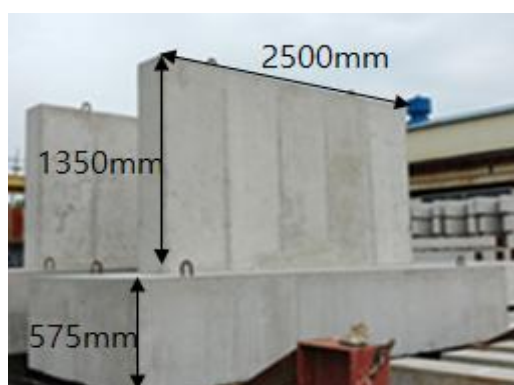

Fig. 3 subassembly test specimen and test set-up

2.2 Veneer specimen

Concrete backing was made of concrete with compressive strength of 35MPa. The dimensions of the wall cross section were length x thickness = 2500 mm x 300 mm,

and the clear height of the wall specimen was 1350 mm. To satisfy the KBC specifications for anchored masonry veneer that at least one anchor for each 0.25 m² of wall area is required, the veneer anchors were installed at intervals of 700 mm horizontally and 335 mm vertically. A 100mm long L-shaped sheet-metal anchors were used. The distance between the inside face of the veneer and outside face of the backing was 55mm so that the veneer anchors embedded in the mortar joint was 45mm long. Masonry veneer was laid in running bond using mortar with compressive strength of 11MPa. To simulate a situation of more than two stories with minimal friction, the masonry veneer was installed on an masonry support and teflon sheet installed at the bottom of the support wall (**Fig.4**).



(a) Dimension of concrete backing



(b) veneer anchor embeded length

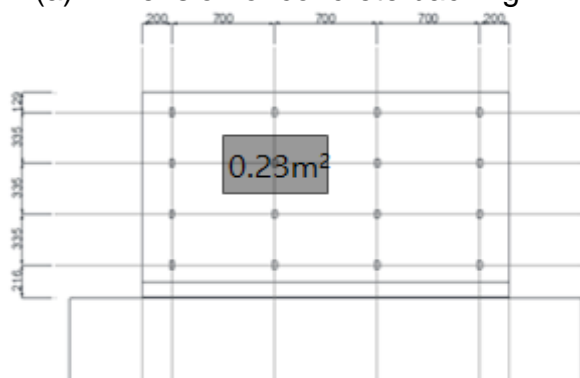

(c) Veneer anchor installation loaction



(d) Masonry support and telon sheet

Fig. 4 Veneer sepcimen (a) Dimension of concrete backing (b) veneer anchor embeded length (c) Veneer anchor installation loaction (d) Masonry support and telon sheet

As shown in **Fig.5**, a 'Whiffle tree' used in MaGinley(2008) and Jo(2010) was constructed to apply an equal distribution load to the masonry veneer through 32 point loads. 'Whiffle tree' consists of one steel beam (H 350 x 350 x 13 x 13), 30 steel tubes (two SHS 150 x 150 x 9, four SHS 100 x 100 x 6, eight plus sixteen SHS 50 x 50 x 6), and 62 threaded rods (four 27 mm. rods, eight 20 mm. rods, sixteen 14 mm. rods, and thirty - two 8 mm. rods). 32 holes were drilled into the masonry veneer and the 'whiffle tree' and the veneer were connected to the camical anchor for the load transfer. 16 strain gauge were attached to eache veneer anchor to estimate the force distribution and total of 12 displacement transducers were installed at the masonry veneer and

concrete backing as shown in **Fig.6**. The 'Whiffle tree' and the actuator were connected to each other, and the loading protocol which consisted of series of three reversed cycles was applied to the veneer by actuator.

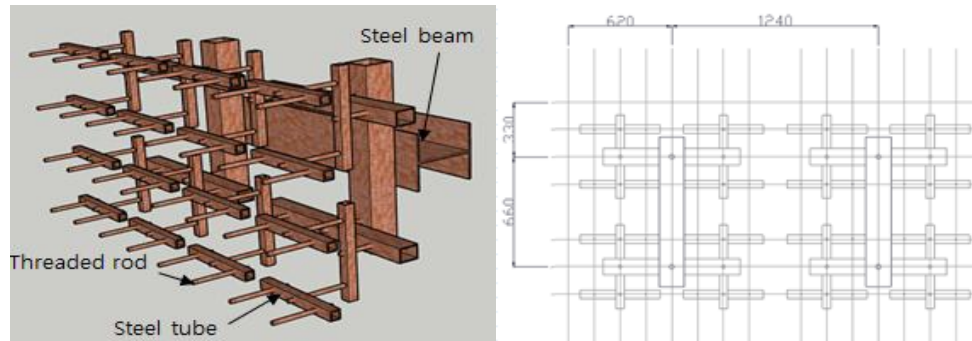

Fig. 5 Whiffle tree

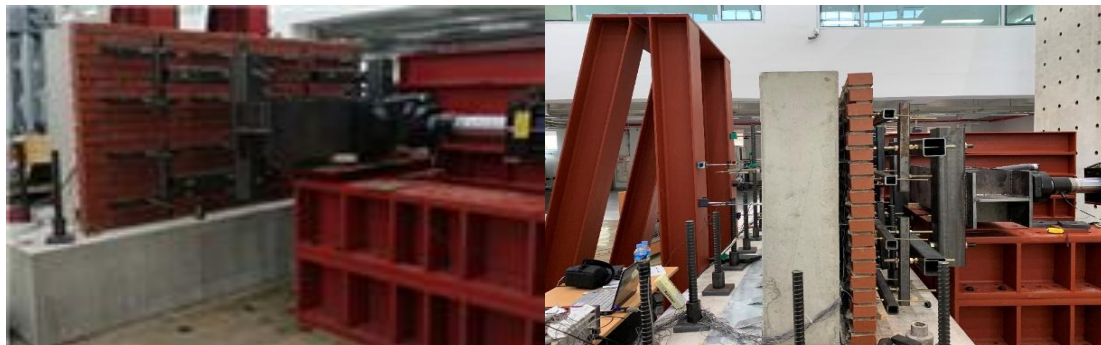

Fig. 6 Installed "Whiffle tree" and set-up of the displacement transducers

4. TEST RESULT

4.1 Subassembly test

Fig. 7 shows the load-displacement relationships of the subassembly specimen 1. When the tension is applied to L-shaped sheet-metal veneer anchor, the spread of anchor occurs and the axis of the graph moves in a tensile direction. The maximum tensile strength of specimen 1 was 1.80kN, and the maximum tensile strength and failure mode of each specimen are presented in **Table 1**. The failure mode of all specimen was the same as that pull out of rawlplug, with the tensile average of the specimen was 1.64kN

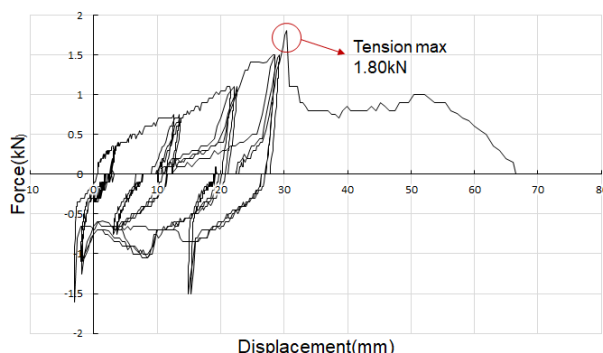

Fig. 7 load-displacement relationships for the subassembly specimen 1

Table 1. Test parameters of specimens

Specimens	Tension(kN)	failure mode
1	1.80	Pull out of rawplug
2	1.10	Pull out of rawplug
3	1.50	Pull out of rawplug
4	2.21	Pull out of rawplug
5	1.60	Pull out of rawplug
ave	1.64	

4.2 Veneer test

Fig.8 (a) shows the curve of load versus displacement at the mid-height of the masonry veneer. In the tension of the first cycle of the second step, the maximum load of 9.41kN was reached without reaching the planned target load of 11.54kN. After the maximum load was reached, there was no increase in load even when the displacement increased, and the following cycle was carried out using the target displacement instead of the target load. **Fig.8 (b)** shows the displacement of the brick wall by height (216mm, 551mm, 886mm,1221mm). The brick veneer wall essentially displayed rigid body rotation about its base like results of Reneckis(2004). However, since the strain is estimated as the displacement difference between the brick veneer wall and the backing wall in Reneckis(2004), the results of the anchor strain measured directly are different. **Fig.8 (c)** is a Force graph of the anchors(6, 8, 11) that are pulled out after several cycles and no longer receive tensile force. The force applied to each anchor was obtained by multiplying the strain of the anchor by the stiffness. Anchors 6, 8, and 11 are the second, fourth anchors of the second row, and third anchor of the third row, respectively. Anchor 8, 6, and 11 don't receive tensile forces from the first cycle of the third step, the first and the last cycle of the fifth step respectively.

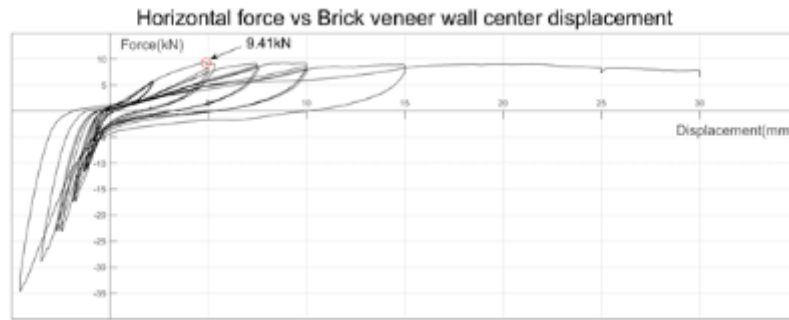

(a) Horizontal force vs Brick veneer wall

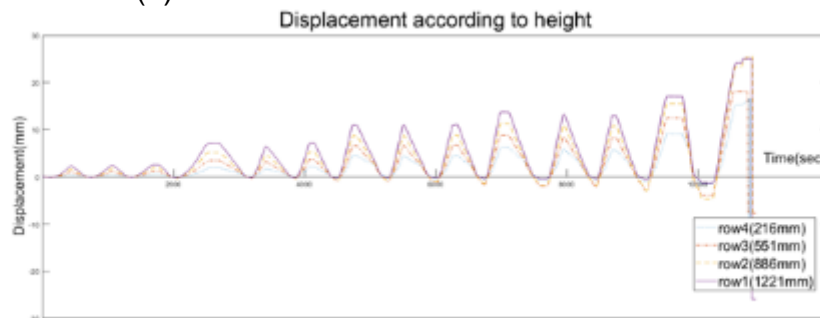

(b) Displacement according to height

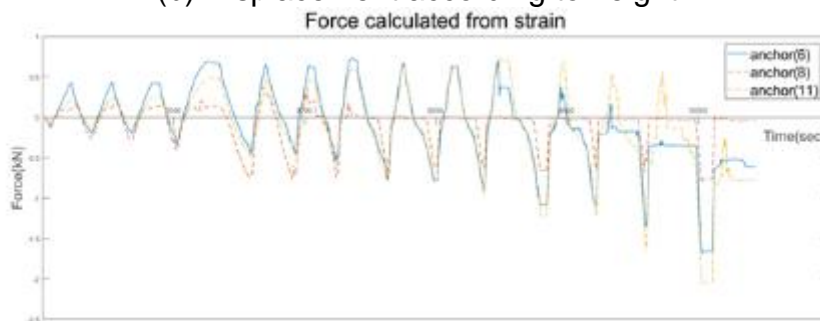

(c) Force calculated from strain

Fig. 8 Graphs of experimental results (a) Horizontal force vs Brick veneer wall displacement (b) Displacement according to height (c) Force calculated from strain

5. CONCLUSIONS

In this study, cyclic lateral loading test for subassembly and masonry veneer were performed to investigate the available design strength of masonry veneer. From the test results, the load carrying capacity of subassembly and veneer, failure mode, displacement according to the height of the veneer, the strain in the veneer anchor were investigated. The main conclusions are as follows:

- (1) Displacement according to the height of the veneer show that the masonry veneer rotated rigidly about its base. This rotation of the masonry veneer

creates a difference in load on the upper and lower veneer anchor, which can be indirectly identified by the strain gauge.

- (2) Unlike rebars that yield in reinforced concrete, the veneer anchor of the masonry veneer is pulled out from the backing or its strength is drastically reduced. Elimination or reduction of strength results in redistribution of the load, and the masonry veneer shows a yield-like behavior with no increase in load even if displacement increases. **(Fig. 8)**
- (3) If only displacement differences for height were taken into account, the out-of-plane strength of the masonry veneer can be expected 59% of the strength of the installed anchors, but in practice, anchors of the same height did not reach the same load at the same time, so the strength of the masonry veneer showed 36% in this experiment.

REFERENCES

- Choi, B.J. (2017). Seismic Design for Nonstructural Elements and Damage of Gyeongju 9.12 Earthquakes. *Magazine of the Korean Society of Steel Construction*, 29 (1), 19-24.
- Choi, Y. H., & LaFave, J. M. (2004). Performance of corrugated metal ties for brick veneer wall systems. *Journal of materials in civil engineering*, 16(3), 202-211.
- Graziotti, F., Tomassetti, U., Penna, A., & Magenes, G. (2016). Out-of-plane shaking table tests on URM single leaf and cavity walls. *Engineering Structures*, 125, 455-470.
- Jo, S. (2010). Seismic behavior and design of low-rise reinforced concrete masonry with clay masonry veneer (Doctoral dissertation).
- Martins, A. P. G., Vasconcelos, G., & Costa, A. C. (2016). Experimental study on the mechanical performance of steel ties for brick masonry veneers. In *16th International Brick and Block Masonry Conference "Masonry in a world of challenges"* (pp. 1723-1731). Taylor & Francis.
- McGinley, W. M., & Hamoush, S. (2008, April). Seismic masonry veneer: Quasi-static testing of wood stud backed clay masonry veneer walls. In *ASCE Structures Congress 2008: Crossing Borders*. ASCE.
- Okail, H. O., Shing, P. B., Klingner, R. E., & McGinley, W. M. (2010). Performance of clay masonry veneer in wood- stud walls subjected to out- of- plane seismic loads. *Earthquake Engineering & Structural Dynamics*, 39(14), 1585-1609.
- Reneckis, D., LaFave, J. M., & Clarke, W. M. (2004). Out-of-plane performance of brick veneer walls on wood frame construction. *Engineering Structures*, 26(8), 1027-1042.
- Yoon, Byungick. (2018). Nonstructural Elements Resulting From Pohang Earthquake and Direction of Future Seismic Design Nonstructural Elements. *Review of Architecture and Building Science*, 62 (4), 23-28.